

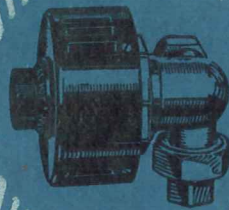

The
Thermotrol

A ROOM TEMPERATURE
CONTROL APPLIED TO
INDIVIDUAL RADIATORS



**STERLING
ENGINEERING CO.
MILWAUKEE, WIS.**

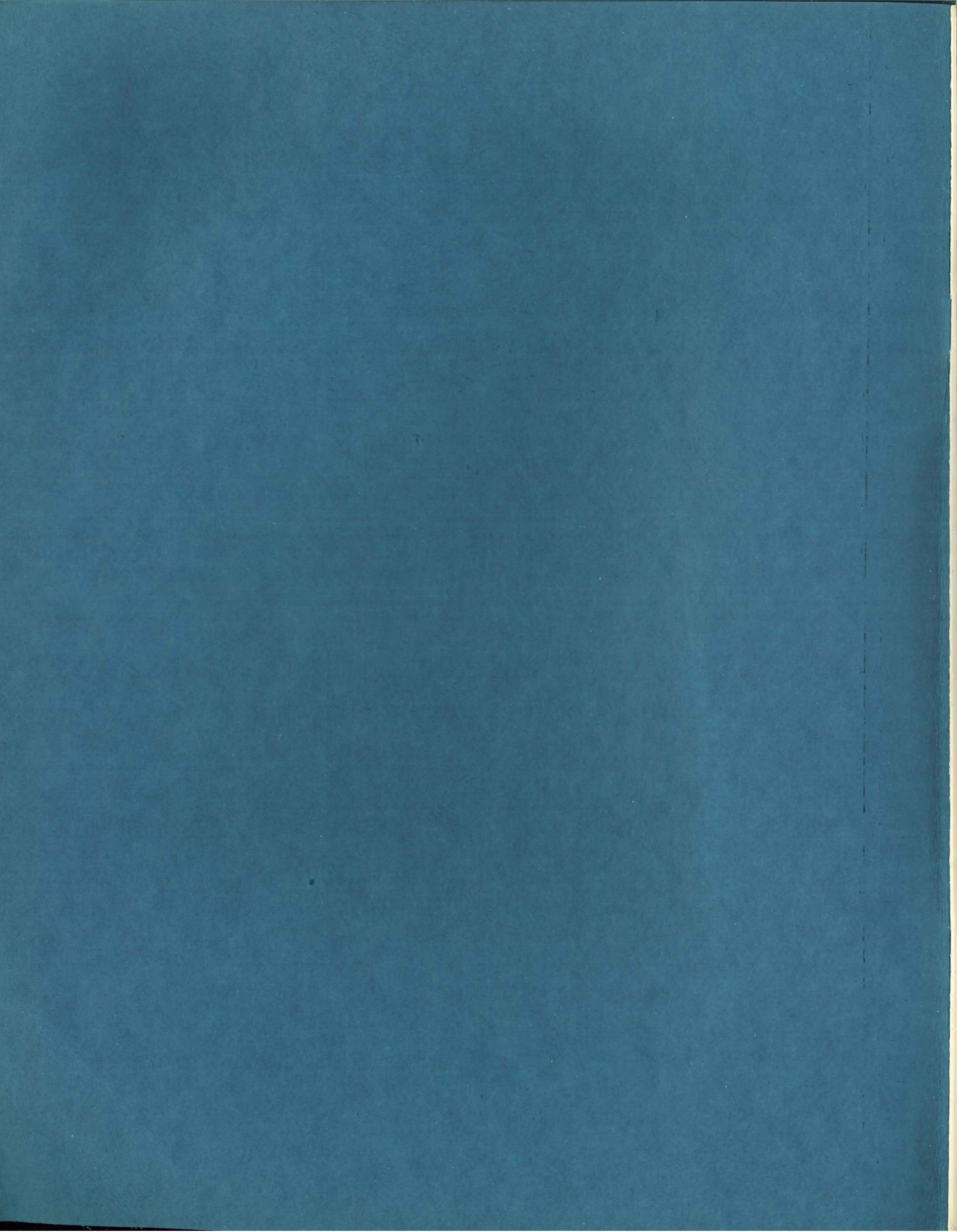

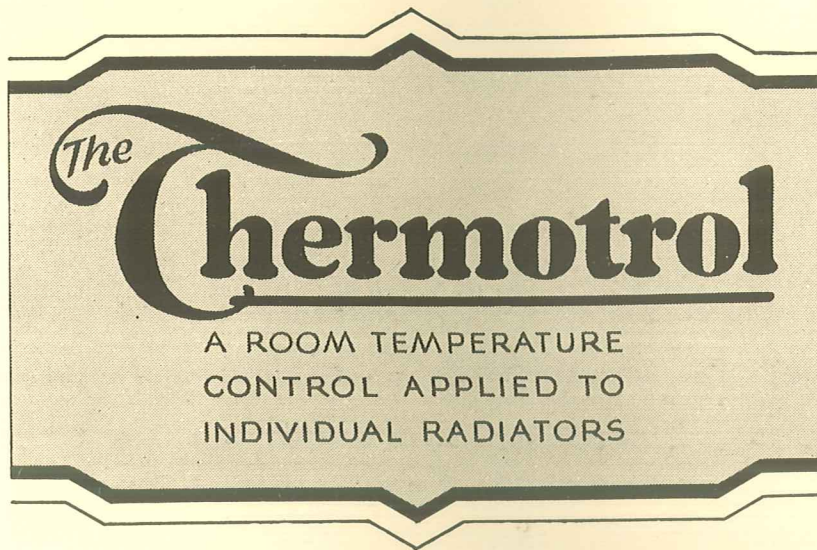

Catalog No. 130

RUSSELL J. SMITH,
St. Louis Representative,

7707 LILE AVE. - ST. LOUIS, MO.
Phone: STerling Thirteen Thirteen

STERLING ENGINEERING COMPANY
MILWAUKEE 1640 Holton Street WISCONSIN

COPYRIGHT, 1930
STERLING ENGINEERING CO.
MILWAUKEE, WIS.

just a bit of history

The principle of individual radiator control has been accepted by heating engineers, for years, as the correct and—ultimately—the prevalent method of regulating room temperatures.

For thirty two years, inventive minds and engineering skill have wrestled with the problem with indifferent success. The first crude instruments—ungainly in size and uncertain in effectiveness—demonstrated the potential possibilities of thermostatic radiator control.

Each succeeding model brought less bulky construction and finer, more dependable control. Each one took advantage of improved engineering developments in refining the elements of design and operation.

The history of the development of individual radiator control methods is the history of the development of Thermotrol.

Thermotrol, as the pioneer, has a background of experience and a record of success that gives double value to its users because it is assurance of known performance and dependable, serviceable design.

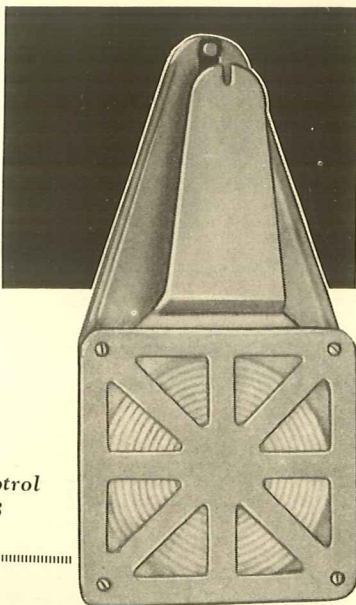

The Thermotrol 1898

Simply stated, the Thermotrol is a radiator valve, thermostatically operated by means of a pressure bellows. It is installed exactly as any radiator valve is applied.

As room temperature varies, the Thermotrol instantly re-acts to the change and increases or reduces the rate of flow of steam or hot water to the radiator. Once it is adjusted to the desired temperature, it automatically maintains that temperature without any further attention.

Thermotrol is universally applicable to two-pipe



steam, vapor, vacuum or hot water heating systems—
from homes to the largest commercial buildings.

In domestic use, it replaces the central thermostat
and—because each radiator is operated as a unit—
it maintains the desired temperature in *every* room.
It does away with the necessity of overheating rooms
on the south side of the house to keep rooms on the
north side comfortably warm. It permits a low
temperature in bed rooms and recreation rooms and
a cozy warmth in the nursery.

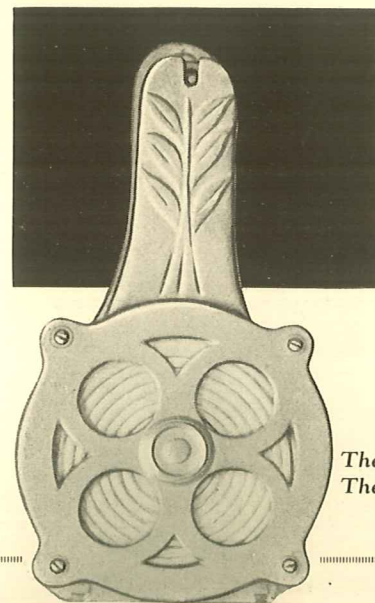

The
Thermotrol
1904

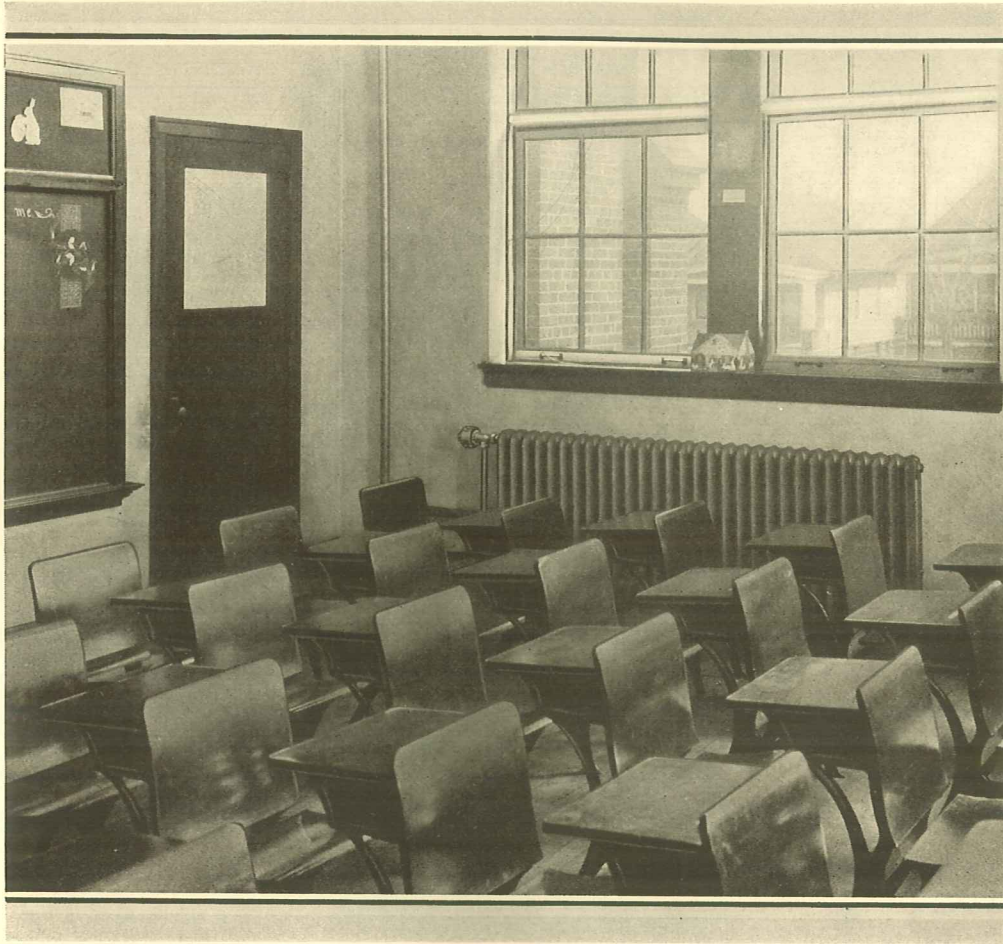

*The
Thermotrol
1915*

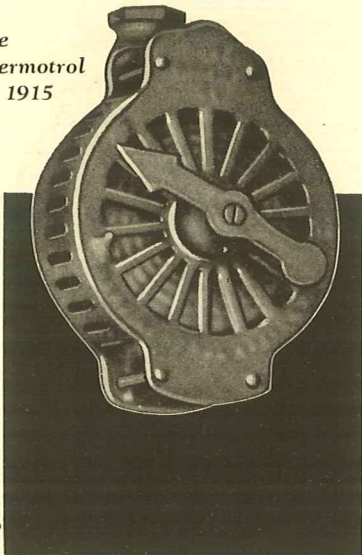

It turns the heat off in the kitchen when cooking or baking would otherwise send the temperature soaring. And when the fireplace is lighted for the cheeriness of its flicker and glow, Thermotrol responds with less heat from the radiators.

In hotels and other commercial buildings, where temperatures are commonly controlled by raising or lowering windows, Thermotrol maintains a comfortable warmth that spells economy in fuel as well as comfort for the occupants.

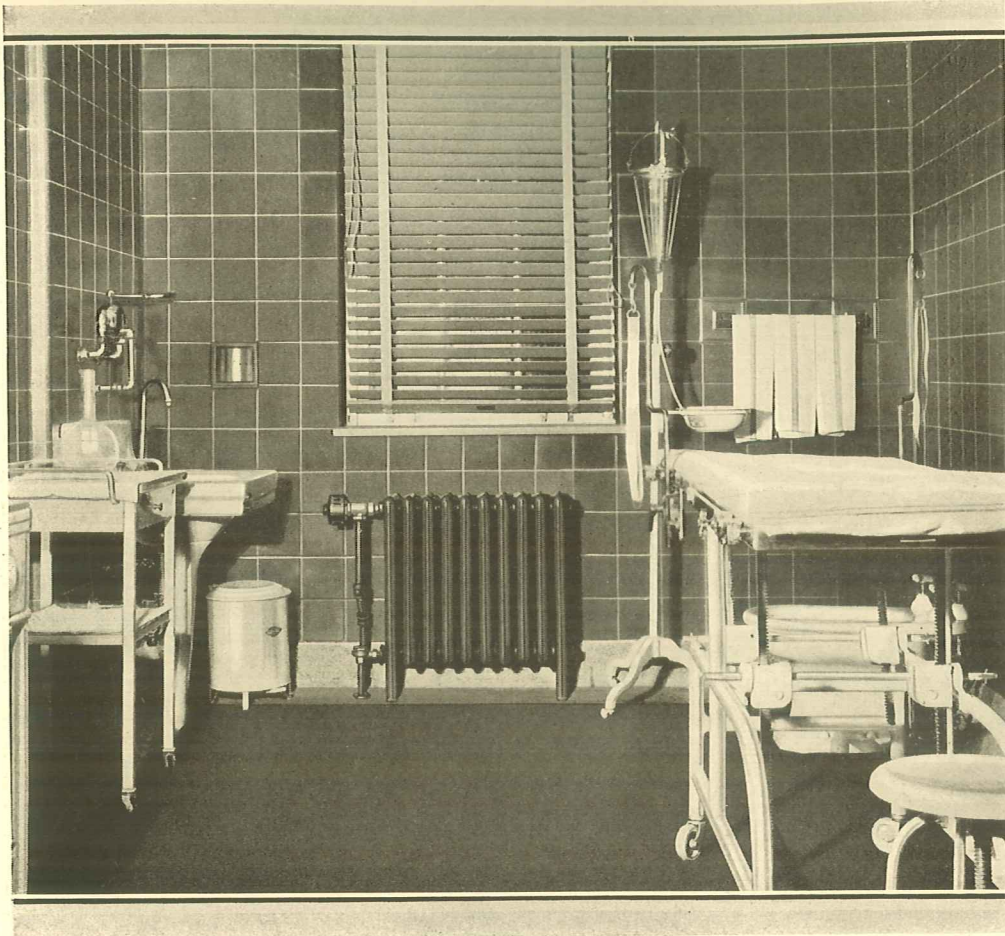

In rooms with large exposures such as auditoriums, gymnasiums, class rooms and churches, the control of individual radiators provides more even heating and greater comfort than any other method because it automatically compensates for changes in wind by applying the most heat where the most is needed.

The old methods of manual control are fast passing, because Thermotrol has put within the reach of everyone a dependable means of securing maximum comfort at a decided saving in fuel costs.

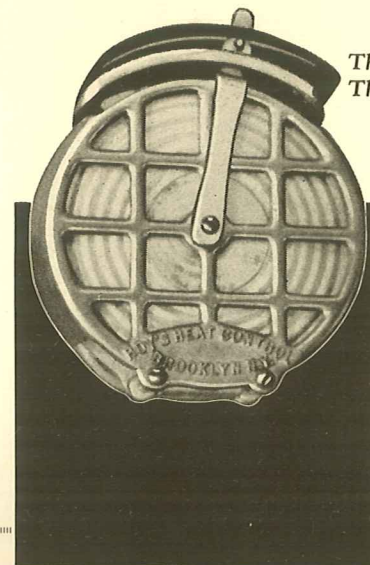

The Thermotrol 1923

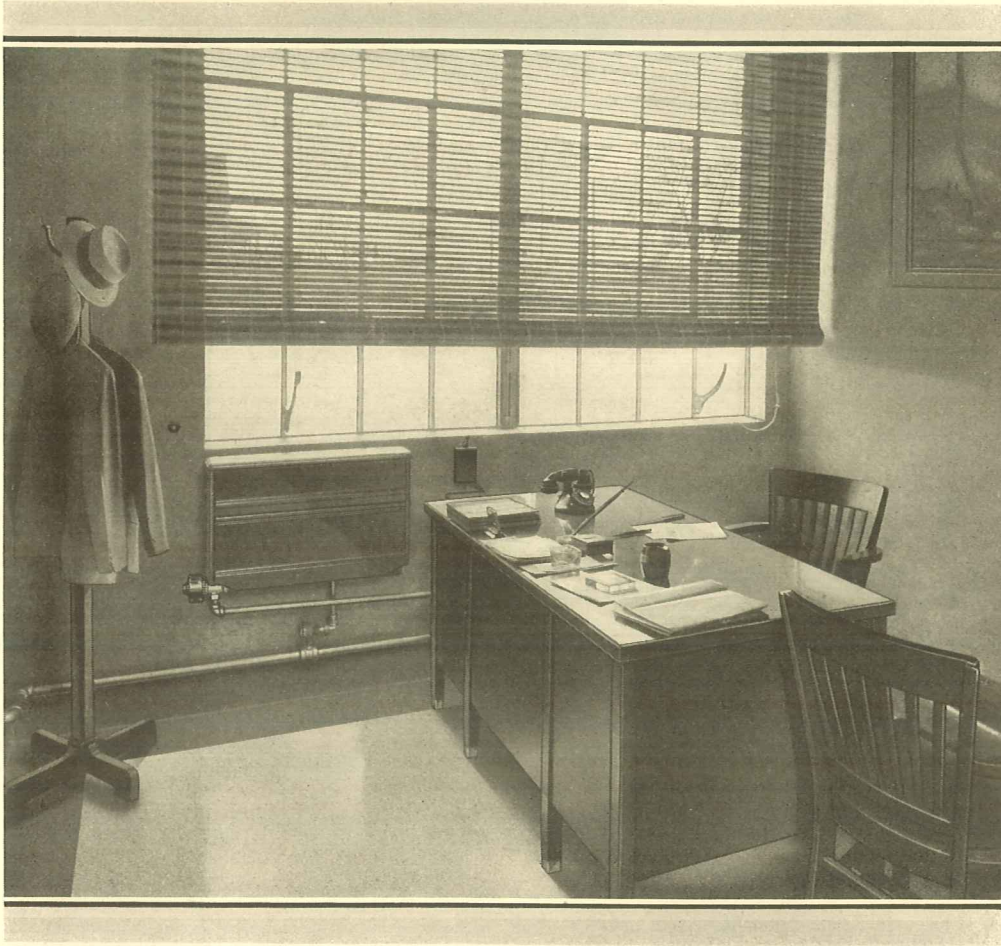

The
Thermotrol
1924

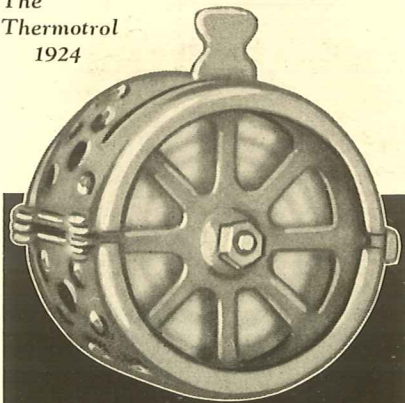

Nearly everyone is thoughtless of the less obvious wastes. Few realize how many pounds of coal it costs to throw a window wide open in zero weather.

Particularly in buildings upon whose operating economies depend profits, the loss through heedless wastes is enormous. Hotels and apartments have shown savings of 25% to 35% in fuel costs after Thermotrols were installed, and savings in domestic installation commonly run from 15% to 30%.

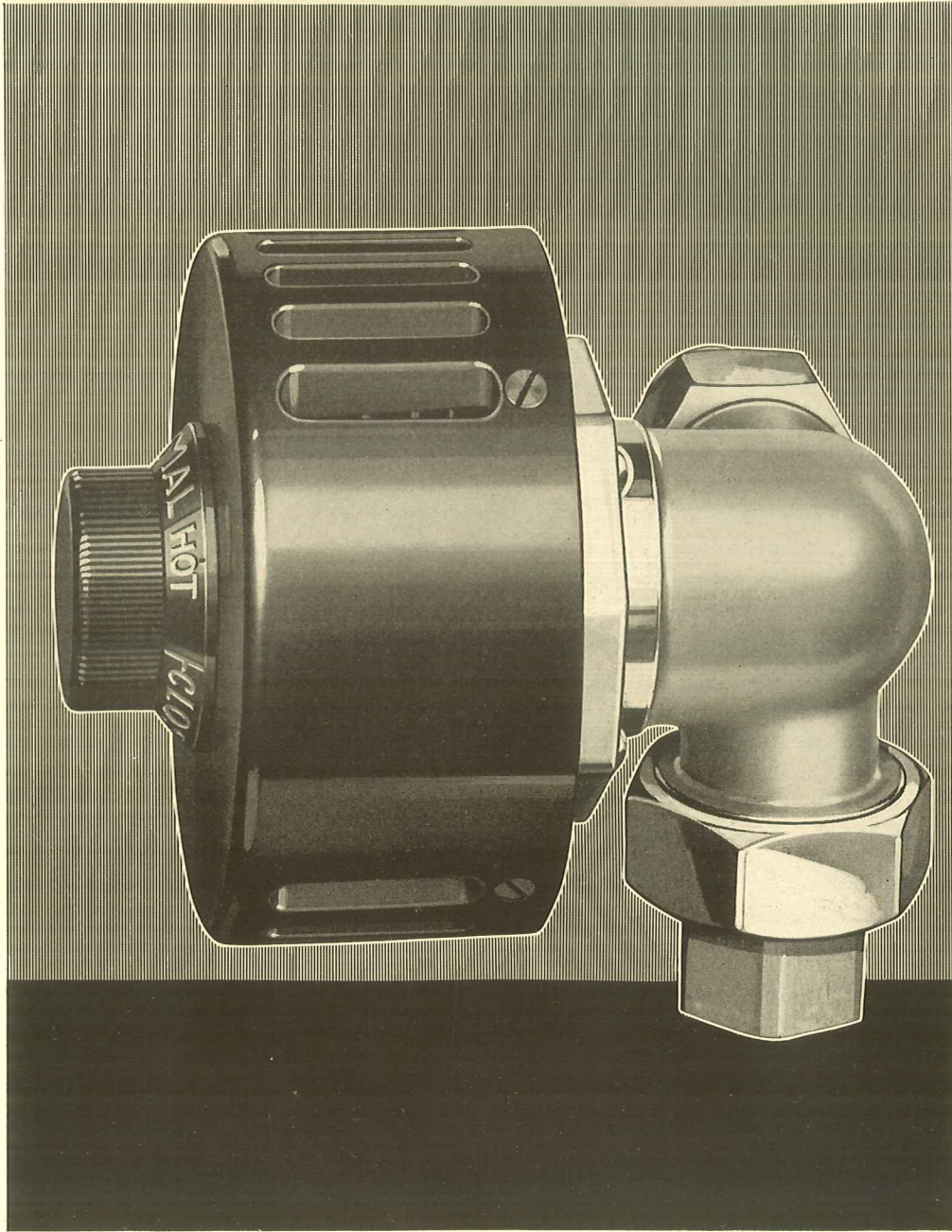

The Thermotrol
(Corner Pattern)

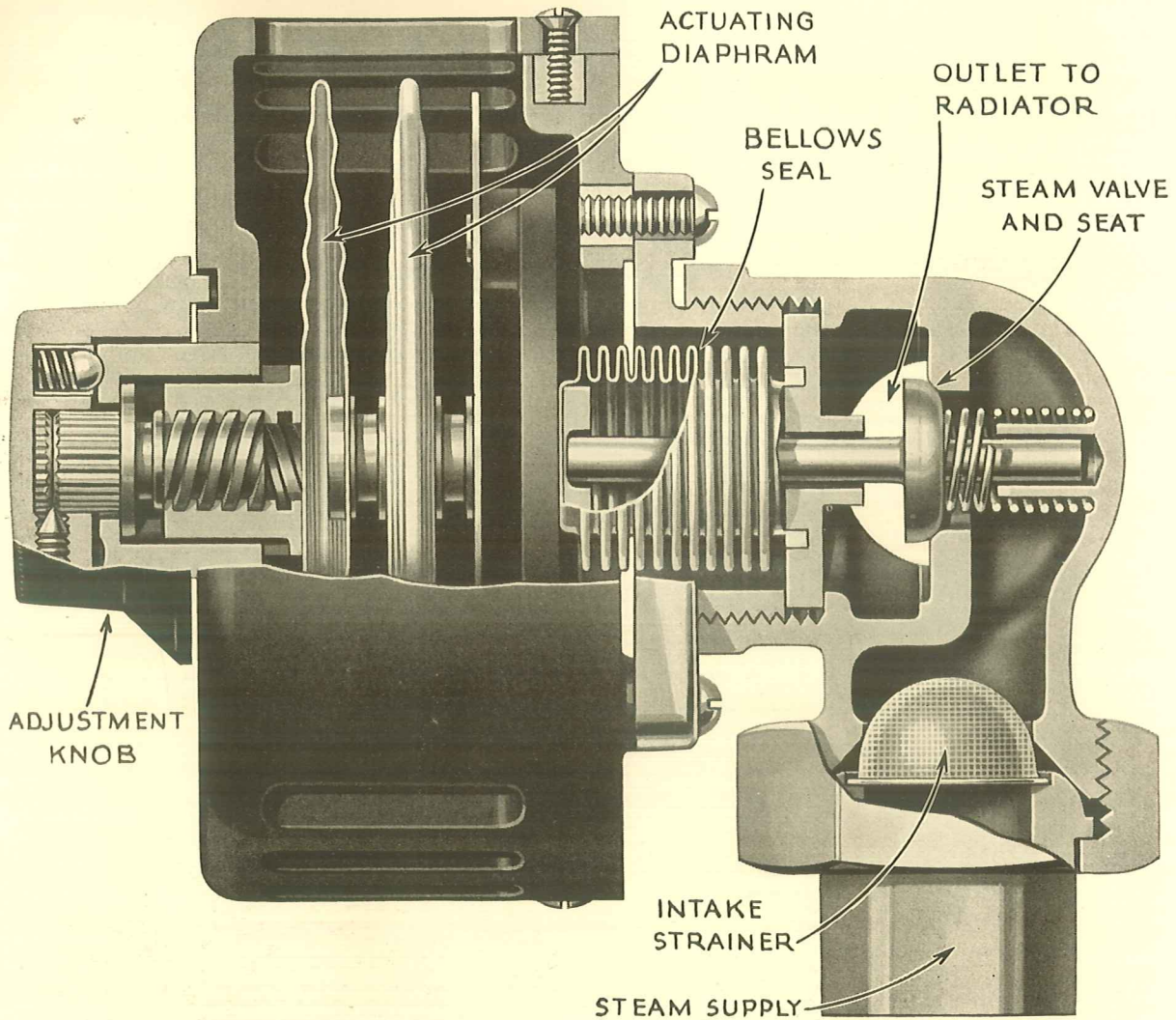

The Thermotrol is sound in principle and simple in construction and adjustment.

Repeated experiments have proven that the temperature of the air at a given distance from a radiator bears a definite relation to the room temperature. It is upon this principle that Thermotrol is designed.

The unit consists of a bronze valve with tapered seat and a guided stem

upon which is mounted the thermostatic control. The valve is so constructed that it operates easily at common heating pressures. The valve mechanism is effectively insulated from the thermostatic unit by means of a metal baffle, Bakelite flanges and the Bakelite housing.

The actuating diaphragms are of special composition and contain a volatile liquid which expands and contracts with change in temperature.

The air about the radiator passes through the Bakelite housing and causes expansion or contraction of the compound actuating diaphragm.

As room temperature rises, these diaphragms expand and transmit the motion in a straight line directly to the valve stem through a Bakelite baffle plate and rolled copper bellows, thereby closing the valve and cutting off the supply of steam.

There is no valve stem stuffing box to leak and affect the accuracy of the thermostatic unit, for the motion of the actuating bellows is transmitted to the valve stem through a rolled copper bellows which forms a positive steam seal.

The bellows and valve are so designed that the unbalanced pressure above and below the valve tends to open the valve. A light spring under the valve adds to its tendency to open. This provision is made to provide positive manual control if automatic features are inoperative.

The adjustment of the Thermotrol is extremely simple, and when once made need never be disturbed unless a higher or lower temperature is desired. In installing the Thermotrol, the control knob should be turned to "NORMAL". If this adjustment is not the desired one, a slight turn toward "HOT" or "COLD" will give the desired change. If no heat is desired, turning the adjustment knob to "CLOSED" will shut the valve off entirely.

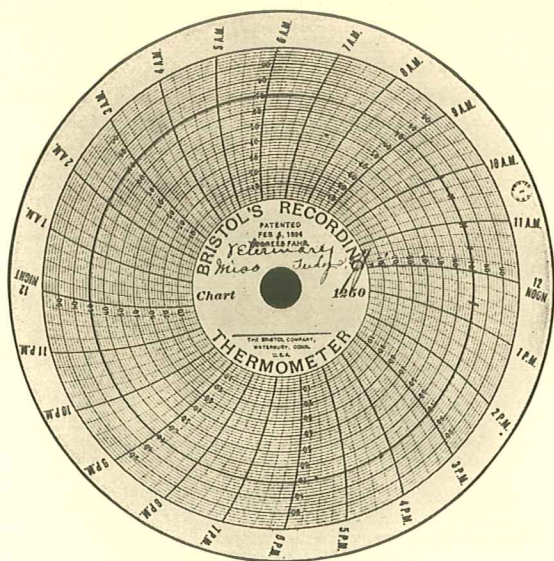

Chart No. 1

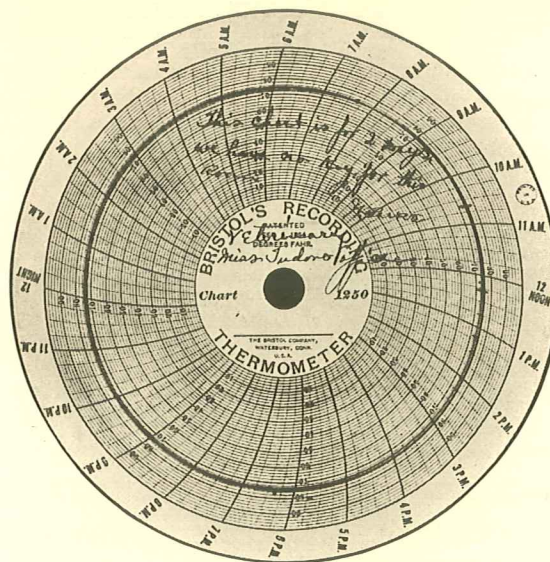
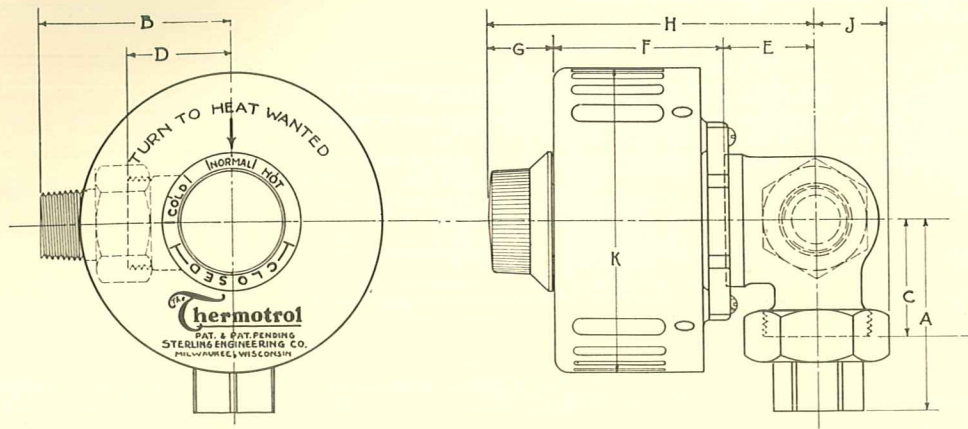

Chart No. 2

Recording thermometer charts showing the results of tests made at the University of Pennsylvania, illustrating the accuracy with which the Thermotrol governs room temperature.

Note that in Chart No. 1, the maximum temperature variation did not exceed 1° in a twenty-four hour period and in Chart No. 2 that it did not exceed 2° in forty-eight hours.



**SIZES—CAPACITIES—ROUGHING-IN DIMENSIONS
THERMOTROL—CORNER PATTERN**

Code Word	Size Inlet & Outlet	Capacity Sq. Ft. of Radiation	A	B	C	D	E	F	G	H	J	K
Cloth	1/2"	50	2 5/8	2 5/8	1 11/16	1 3/8	1 3/16	2 7/16	1 5/16	4 9/16	7/8	4 3/8
Cube	3/4"	100	2 3/4	2 3/4	1 11/16	1 11/16	1 5/16	2 7/16	1 5/16	4 11/16	1 1/16	4 3/8
Cone	1"	200	3	3	1 13/16	1 3/4	1 1/2	2 7/16	1 5/16	4 7/8	1 3/16	4 3/8
Core	1 1/2"	350	3 3/4	3 3/4	2	2	1 5/8	2 7/16	1 5/16	5	1 1/2	4 3/8



The Hand Adjustable type is easily set for any desired heat by moving a plainly marked knob to the desired position. This type may be adjusted by anyone at will.



The Loose Key type is designed for installations where it is desired to keep heat control in the hands of authorized persons. It is adjusted by means of a loose key and may not be changed without it.

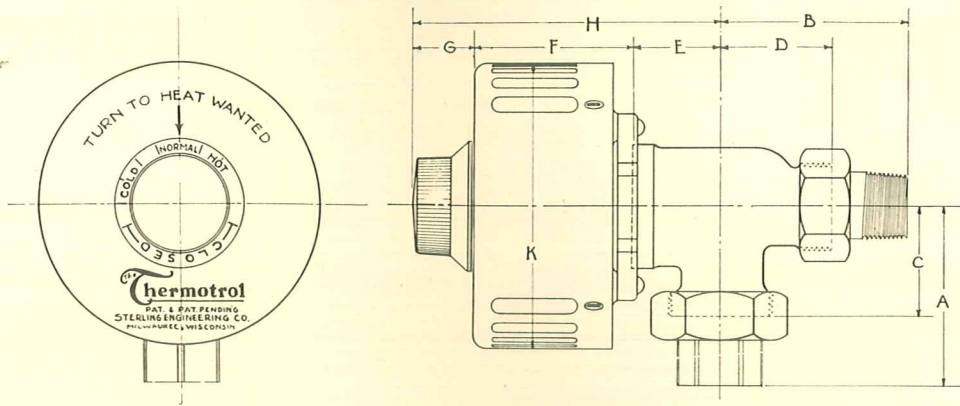

SIZES—CAPACITIES—ROUGHING-IN DIMENSIONS
THERMOTROL—ANGLE PATTERN

Code Word	Size Inlet & Outlet	Capacity Sq. Ft. of Radiation	A	B	C	D	E	F	G	H	K
Coal	1/2"	50	2 5/8	2 5/8	1 11/16	1 3/8	1 3/16	2 7/16	1 5/16	4 9/16	4 3/8
Cure	3/4"	100	2 3/4	2 3/4	1 11/16	1 11/16	1 5/16	2 7/16	1 5/16	4 11/16	4 3/8
Cake	1"	200	3	3	1 13/16	1 3/4	1 1/2	2 7/16	1 5/16	4 7/8	4 3/8
Calf	1 1/2"	350	3 3/4	3 3/4	2	2	1 5/8	2 7/16	1 5/16	5	4 3/8

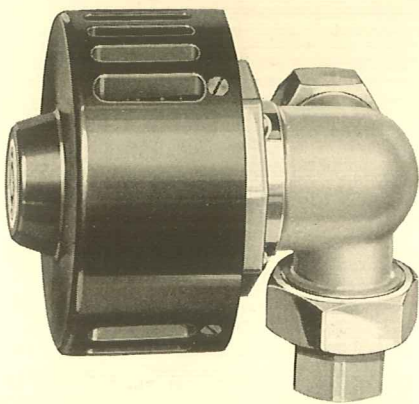

The Corner pattern Thermotrol—made either right or left hand.

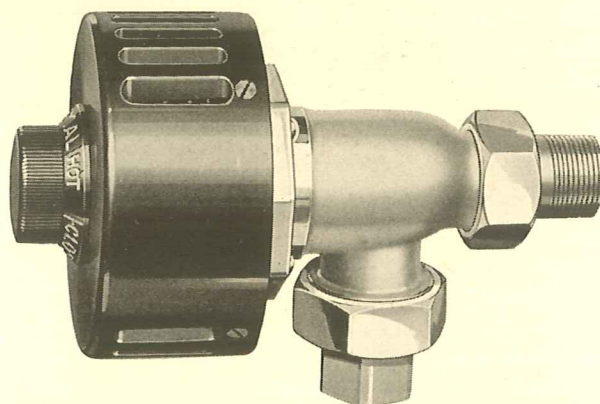

The Angle pattern Thermotrol—for installations where space is ample.



Infirmery of University of Oklahoma. Completely equipped with Thermotrols.

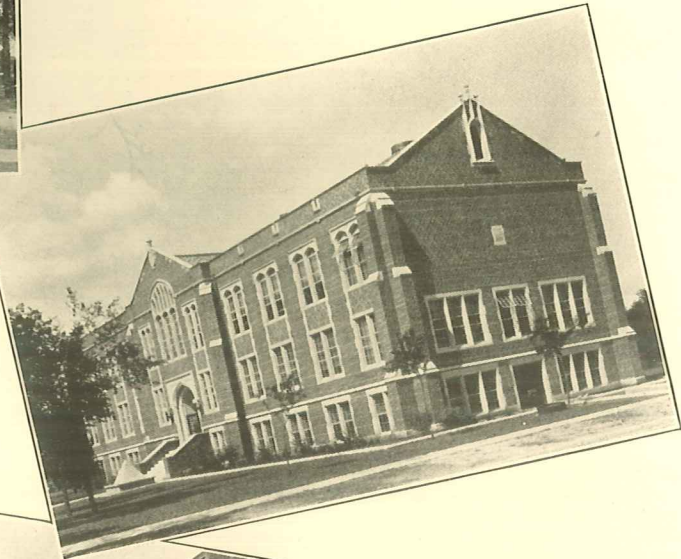

Engineering Building of University of Oklahoma. Completely equipped with Thermotrols.

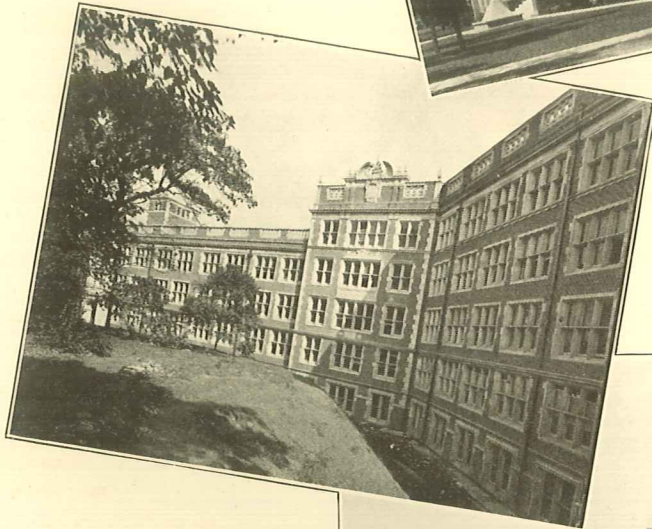

Laboratory of Anatomy and Physiological Chemistry Building of University of Pennsylvania. Completely equipped with Thermotrols.



Security Benefit Hospital, Topeka, Kansas. Completely equipped with Thermotrols.

Guarantee

THE Sterling Engineering Company guarantees that the Thermotrol will control the amount of heat radiated from the radiator to which it is attached so as to maintain a room temperature within 1° F. above and 1° F. below the point of adjustment provided:

1. That the temperature of the room is not affected by any source of heat other than the radiator to which the Thermotrol is attached.
2. That all doors and windows are kept closed.
3. That a sufficient and continuous supply of steam is furnished to the radiator, and that there is sufficient radiation to heat the room to the required temperature.
4. That the radiator is continuously properly vented and properly drained.

The temperature of the room shall be determined by means of a recording test thermometer placed at approximately the center of the room and five feet above the floor but not within eight feet of the radiator or within three feet of an outside wall.

The Sterling Engineering Company guarantees the Thermotrol to be free from defects in workmanship and material under normal use and service. The Company's obligations under this guarantee are limited to repairing or refurnishing at its factory any part or parts, which shall, within three years after delivery of equipment to the original purchaser, be returned, transportation prepaid, and which on examination shall disclose to its satisfaction to have been thus defective.

The Company neither assumes nor authorizes any other person or persons to assume for it any liabilities in connection with the sale of the Thermotrols except under the conditions of this guarantee.

This Guarantee will become null and void if the Thermotrol, or Thermotrols, which are claimed defective, have been taken apart or repaired by others than the Company or its representatives.

Standard Specification

INSTALL at the supply end of each radiator a Thermotrol temperature control valve, as manufactured by the Sterling Engineering Company of Milwaukee, Wisconsin.

This control valve consists of a bronze valve on which is mounted a thermostatic unit consisting of a compound diaphragm enclosed in a Bakelite housing and equipped with an adjusting knob. (Either Hand Adjustable or Loose Key type—see cuts at bottom of Page 12).

The control valve shall be of the straight line type so constructed that the action of the diaphragm is conveyed to the valve stem along a straight line. The valve shall have no levers, cams or other devices for changing the line of direction in transmitting the diaphragm motion to the valve stem.

The control valve shall be so designed that it can be tightly closed, manually, when it is desirable to prevent any heat from entering the radiator regardless of room temperature.

The control valve shall be designed to maintain any desired room temperatures between...° F. and...° F. and shall be guaranteed to be free from mechanical defects.

Note to Architects
and
Engineers

Thermotrols will operate on any vacuum, vapor or two-pipe steam heating system or hot water heating system and can be furnished to operate at any desired room temperature. The stock control is designed to close when in the wide open position at approximately 8° F above the temperature at which it would close when set at the point marked NORMAL on the regulating dial.

780 - 45

